

Classificação Aplicações

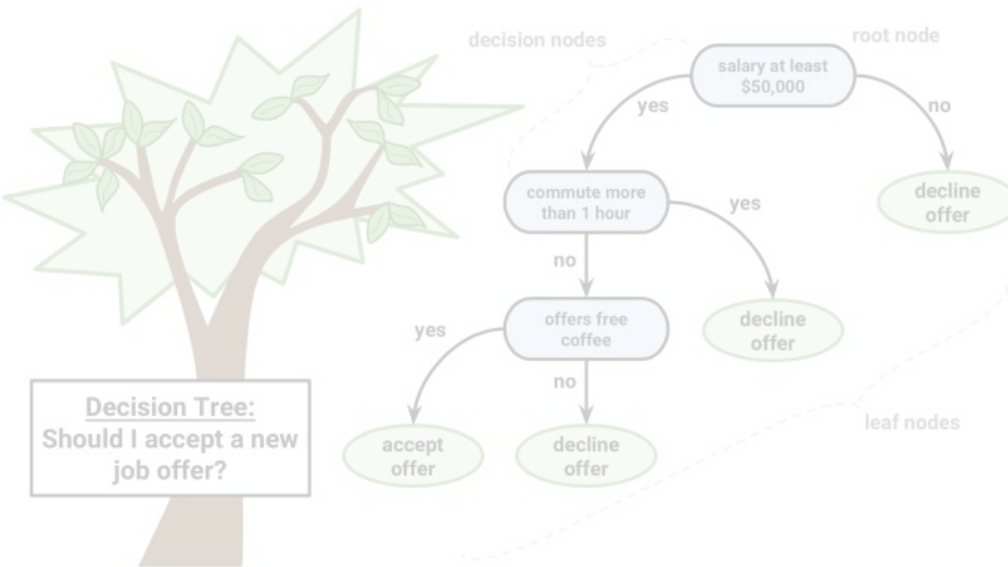

$$P(c|x) = \frac{P(x|c)P(c)}{P(x)}$$

Likelihood: $P(x|c)$
Class Prior Probability: $P(c)$
Posterior Probability: $P(c|x)$
Predictor Prior Probability: $P(x)$

$$P(c|X) = P(x_1|c) \times P(x_2|c) \times \dots \times P(x_n|c) \times P(c)$$

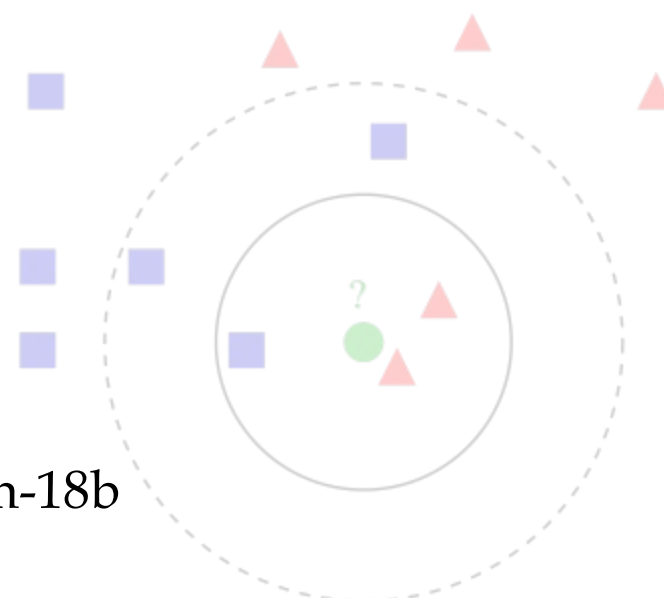

David Menotti

www.inf.ufpr.br/menotti/am-18b

Hoje

- Aplicações em:
 - Árvores de Decisão
 - Aprendizagem Bayesiana
 - Aprendizado por Instância (k-NN)

Árvores de Decisão

Árvores de Decisão

Agenda

- Decision Trees for Fast Security Assessment of Autonomous **power systems** with a large penetration from Renewables (1995)
- Misfire identification in a four-stroke four-cylinder **petrol engine** using decision tree (2010)
- Vibration based fault diagnosis of **monoblock centrifugal pump** using decision tree (2010)

Decision Trees for Fast Security Assessment of Autonomous **power systems** with a large penetration from Renewables (1995)

Introdução

- Uso de árvores de decisão para **avaliar** um **sistema elétrico autônomo** de porte médio com grande penetração de energias renováveis
 - Cenário: Ilha grega de Lemnos
 - Grande potencial eólico (10MW / 25 MW)
- Problema: margem de segurança
 - *Load margin - forecasting errors*
 - *Wind margin - wind forecasting errors*
 - *A dynamic security margin*

Decision Trees for Fast Security Assessment of Autonomous **power systems** with a large penetration from Renewables (1995)

A rede em estudo

- PV - Plantas *Photovoltaics*
- WP - *Wind Parks*
- DPS - Diesel Power Station
- 5 - buses
- 6 types of loads:
 - *Lighting* (2)
 - *Termal* (1)
 - *Motor* (3)

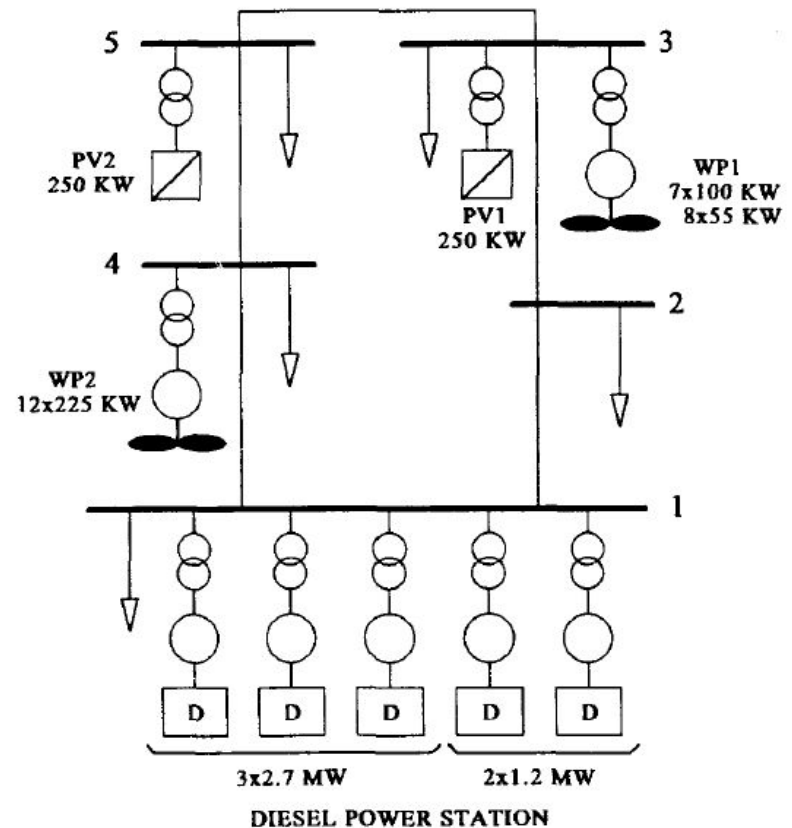

Figure 1. One line diagram of the power system of Lemnos island.

Decision Trees for Fast Security Assessment of Autonomous **power systems** with a large penetration from Renewables (1995)

Modelando o problema

- Given a load demand P_L + Total wind power P_W + PV power P_{PV} , the DUs power (P_D) is

$$P_D = P_L - P_W - P_{PV}$$

- *WM required Wind Margin*
- $P_{DN,min}$ - the minimum necessary nominal capacity

$$P_{DN,min} = P_D + WM \times P_W$$

- Assim 11 valores de $P_{DN,min}$ são possíveis (1.2MW to 10.5MW)
- P_{PV} (solar) é contínua

Decision Trees for Fast Security Assessment of Autonomous **power systems** with a large penetration from Renewables (1995)

A base de aprendizado

- *Learning Set (LS) / Test Set (TS)*
 - *Predetermined - Operating points (OP)*
 - 1800 pontos (apenas realísticos)
 - $P_D \geq 0.25 P_{DN}$
 - $P_W \leq 0.75 P_L$
 - OPs é seguro se **freq** < 1Hz

Set	Total OPs	Safe OPs	Unsafe OPs
LS	1177	722 (61.34 %)	455 (38.66 %)
TS	588	353 (60.03 %)	235 (39.97 %)

Table 1. Safe and Unsafe OPs in LS and TS.

Decision Trees for Fast Security Assessment of Autonomous **power systems** with a large penetration from Renewables (1995)

Atributos

- De 47 possíveis (8 apenas / 95% de acurácia)

1. $P_{D,nom}$: nominal capacity (MW) of **operating** DUs.
2. $P_{D,tot}$: total DPS active power (MW).
3. $P_{D\%} = \frac{P_{D,tot}}{P_{D,nom}}$: DUs loading, % of rated capacity.
4. $S.R. = P_{D,nom} - P_{D,tot}$: DPS spinning reserve.
5. $P_{WP,tot}$: total active output power (MW) of WPs 1&2.
6. $W.M. = \frac{S.R.}{P_{WP,tot}}$: wind margin.
7. $P_{L,tot}$: total active load (MW).
8. $W.P. = \frac{P_{WP,tot}}{P_{L,tot}}$: wind penetration.

Decision Trees for Fast Security Assessment of Autonomous **power systems** with a large penetration from Renewables (1995)

Árvore de decisão resultante

- Notação

NON TERMINAL NODE

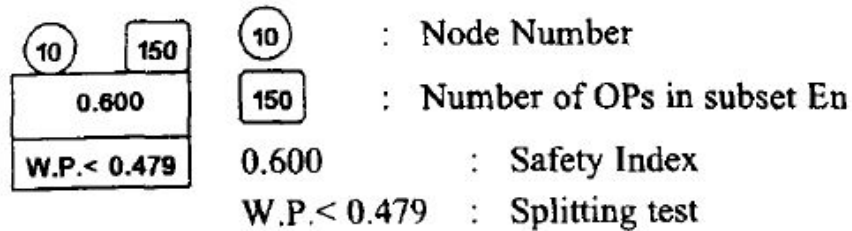

TERMINAL NODE

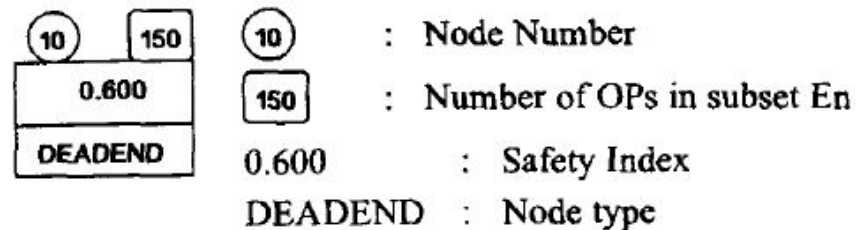

Figure 3. Notation of the DTs' nodes.

Árvore de decisão resultante

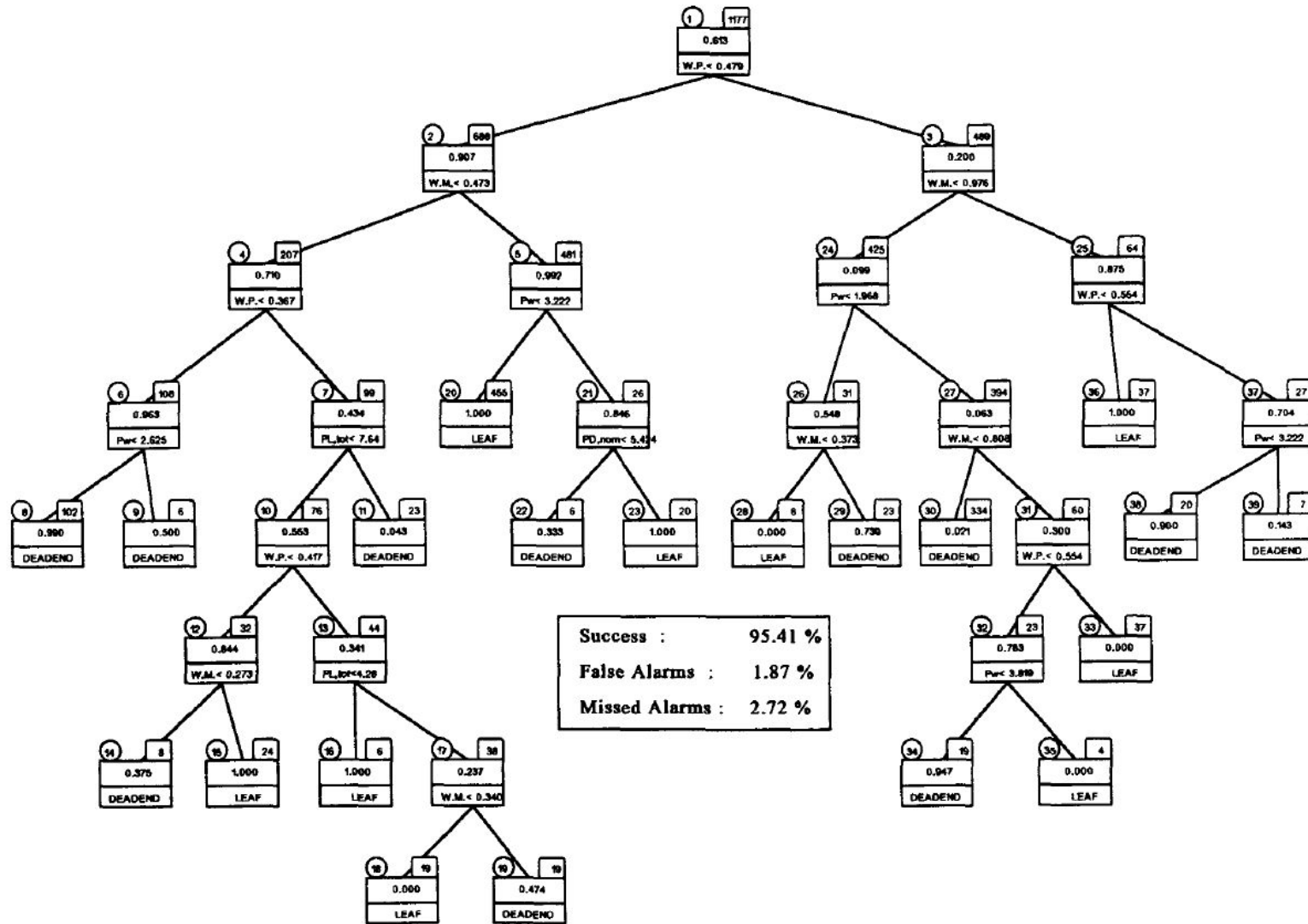

Figure 4. DT developed using the 8 attributes set and χ^2 -test number 1 with 0.9985 confidence level.

Decision Trees for Fast Security Assessment of Autonomous **power systems** with a large penetration from Renewables (1995)

Resultado no *Test Set*.

Node Number	Node Type	Safety Index	Tested OPs	Success % (OPs)	False Alarms % (OPs)	Missed Alarms % (OPs)
8	DEADEND	0.990	44	100.0 (44)	0.0 (0)	0.0 (0)
9	DEADEND	0.500	2	50.0 (1)	50.0 (1)	0.0 (0)
11	DEADEND	0.043	12	91.7 (11)	8.3 (1)	0.0 (0)
14	DEADEND	0.375	2	0.0 (0)	100.0 (2)	0.0 (0)
15	LEAF	1.000	10	100.0 (10)	0.0 (0)	0.0 (0)
16	LEAF	1.000	5	100.0 (5)	0.0 (0)	0.0 (0)
18	LEAF	0.000	5	100.0 (5)	0.0 (0)	0.0 (0)
19	DEADEND	0.474	6	50.0 (3)	50.0 (3)	0.0 (0)
20	LEAF	1.000	237	99.2 (235)	0.0 (0)	0.8 (2)
22	DEADEND	0.333	6	100.0 (6)	0.0 (0)	0.0 (0)
23	LEAF	1.000	9	100.0 (9)	0.0 (0)	0.0 (0)
28	LEAF	0.000	3	100.0 (3)	0.0 (0)	0.0 (0)
29	DEADEND	0.739	15	66.7 (10)	0.0 (0)	33.3 (5)
30	DEADEND	0.021	175	97.7 (171)	2.3 (4)	0.0 (0)
33	LEAF	0.000	11	100.0 (11)	0.0 (0)	0.0 (0)
34	DEADEND	0.947	13	61.5 (8)	0.0 (0)	38.5 (5)
35	LEAF	0.000	1	100.0 (1)	0.0 (0)	0.0 (0)
36	LEAF	1.000	16	100.0 (16)	0.0 (0)	0.0 (0)
38	DEADEND	0.900	9	55.6 (5)	0.0 (0)	44.4 (4)
39	DEADEND	0.143	7	100.0 (7)	0.0 (0)	0.0 (0)

Table 2. Terminal node test record for the DT of Figure 4, using the TS of 588 OPs.

Decision Trees for Fast Security Assessment of Autonomous **power systems** with a large penetration from Renewables (1995)

Discussão

- Importância dos atributos

The 5 attributes appearing in the node splitting tests of the DT of Figure 4 in decreasing significance order are:

Wind Penetration, W.P.

Wind Margin, W.M.

Total Wind Power, $P_{WP, tot}$

Total Load Demand, $P_{L, tot}$

DPS Operating Capacity, $P_{D, nom}$

Decision Trees for Fast Security Assessment of Autonomous **power systems** with a large penetration from Renewables (1995)

Discussão

- Tamanho da rede vs *confidence level*

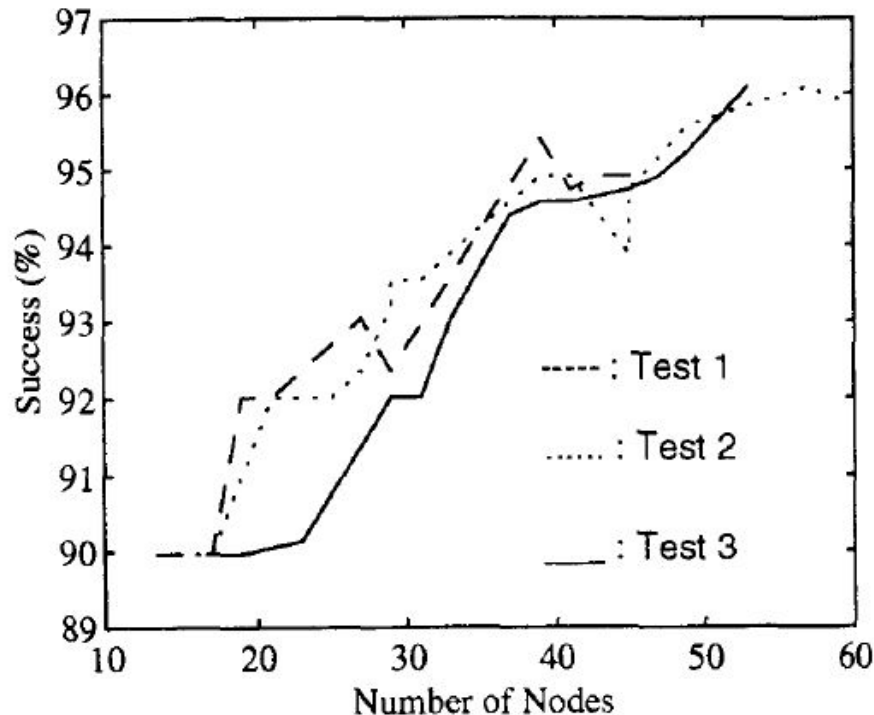

Figure 5. DTs rate of classification success against the number of nodes, for the three X^2 -tests.

Decision Trees for Fast Security Assessment of Autonomous **power systems** with a large penetration from Renewables (1995)

Usar on-line

- Uma árvore de decisão pode ser facilmente convertida em um conjunto de regras.
 - Analisadas sequencialmente
 - IF ... THEN ... ELSE
- Seleção de diferentes árvores com requisitos / preferências diferentes
 - Margem de seguranças pequenas inicialmente
- Pela análise de um ramo “unsafe” pode-se buscar alterar o estado para “safe”

Aprendizagem Bayesiana

Aprendizagem por Instância
Os k -Vizinhos Mais Próximos
 k -Nearest Neighbor

Aprendizagem Bayesiana

Agenda

- Discriminant analysis of wood-based materials using near-infrared spectroscopy (2003)
- A Novel Continuous KNN Prediction Algorithm to Improve Manufacturing Policies in a VMI Supply Chain (2014)
- Evidential KNN-based condition monitoring and early warning method with applications in power plant (2018)

A Novel Continuous KNN Prediction Algorithm to Improve Manufacturing Policies in a [VMI Supply Chain](#) (2014)

Introdução

- *This paper examines and compares various manufacturing policies which a manufacturer may adopt so as to improve the performance of a supply chain under **vendor managed inventory** (VMI) partnership.*
- *The goal is to maximize the combined cumulative profit of supply chain while minimizing the relevant inventory management costs.*
- *The supply chain is a two-level system with a single manufacturer single retailer at each level, in which the manufacturer takes the responsibility of overall inventories of supply chain.*

A Novel Continuous KNN Prediction Algorithm to Improve Manufacturing Policies in a [VMI Supply Chain](#) (2014)

Introdução

- *A base system dynamics (SD) simulation model is first employed to describe the dynamic interactions between the variables and parameters of manufacturer and retailer under VMI.*

A Novel Continuous KNN Prediction Algorithm to Improve Manufacturing Policies in a [VMI Supply Chain](#) (2014)

Problema

- *A base system dynamics (SD) simulation model is first employed to describe the dynamic interactions between the variables and parameters of manufacturer and retailer under VMI.*

Referências

- **Árvores de Decisão**

- N. D. Hatziaargyriou, S. A. Papathanassiou and M. P. Papadopoulos,
Decision trees for fast security assessment of autonomous power systems with a large penetration from renewables,
IEEE Transactions on Energy Conversion, vol. 10, no. 2, pp. 315-325, **1995**.
<https://doi.org/10.1109/60.391898>
- S. Babu Devasenapati, V. Sugumaran, K.I. Ramachandran,
Misfire identification in a four-stroke four-cylinder petrol engine using decision tree,
Expert Systems with Applications, Volume 37, Issue 3, Pages 2150-2160, **2010**,
ISSN 0957-4174, <https://doi.org/10.1016/j.eswa.2009.07.061>
- N.R. Sakthivel, V. Sugumaran, S. Babudevasenapati,
Vibration based fault diagnosis of monoblock centrifugal pump using decision tree,
Expert Systems with Applications, Volume 37, Issue 6, Pages 4040-4049, **2010**,
ISSN 0957-4174, <https://doi.org/10.1016/j.eswa.2009.10.002>.

Referências

- **Aprendizagem Bayesiana**

- O. Addin, S.M. Sapuan, E. Mahdi, M. Othman,
A Naïve-Bayes classifier for damage detection in engineering materials,
Materials & Design, Volume 28, Issue 8, **2007**, Pages 2379-2386, ISSN 0261-3069,
<https://doi.org/10.1016/j.matdes.2006.07.018>.
- Y. Huang, R. McMurran, G. Dhadyalla, R. P. Jones",
Probability based vehicle fault diagnosis: Bayesian network method,
Journal of Intelligent Manufacturing, Volume 19, Issue 3, **2008**, Pages 301-311, ISSN
1572-8145, <https://doi.org/10.1007/s10845-008-0083-7>.
- V. Muralidharan, V. Sugumaran,
A comparative study of Naïve Bayes classifier and Bayes net classifier for fault diagnosis
of monoblock centrifugal pump using wavelet analysis,
Applied Soft Computing, Volume 12, Issue 8, **2012**, Pages 2023-2029, ISSN 1568-4946,
<https://doi.org/10.1016/j.asoc.2012.03.021>.
- Han-joon Kim, Jiyun Kim, Jinseog Kim, Pureum Lim,
Towards perfect text classification with Wikipedia-based semantic Naïve Bayes learning,
Neurocomputing, Volume 315, **2018**, Pages 128-134,
ISSN 0925-2312, <https://doi.org/10.1016/j.neucom.2018.07.002>.

Referências

- **Aprendizagem por Instância**

- M. Akhbari, Y. Zare Mehrjerdia, H. Khademi Zarea, A. Makuib
A Novel Continuous KNN Prediction Algorithm to Improve Manufacturing Policies in a VMI Supply Chain
International Journal of Engineering (IJE) Transactions B: Applications, Vol. 27, No. 11, **2014**, Pages 1681-1690.
- Xiao-long Chen, Pei-hong Wang, Yong-sheng Hao, Ming Zhao,
Evidential KNN-based condition monitoring and early warning method with applications in power plant,
Neurocomputing, Volume 315, **2018**, Pages 18-32,
ISSN 0925-2312, <https://doi.org/10.1016/j.neucom.2018.05.018>.
- S. Tsuchikawa and K. Yamato, K. Inoue
Discriminant analysis of wood-based materials using near-infrared spectroscopy,
Journal of Wood Science, Volume 49, Issue 3, **2003**, Pages 275-280,
ISSN 1435-0211, <https://doi.org/10.1007/s10086-002-0471-0>

Referências

- Artigos estudados estão disponíveis em:
 - www.inf.ufpr.br/menotti/am-18b/papers.zip